

livani®

Instalation manual
Notice de pose
Instrukcja montażu
Guía de instalación
Istruzioni di montaggio

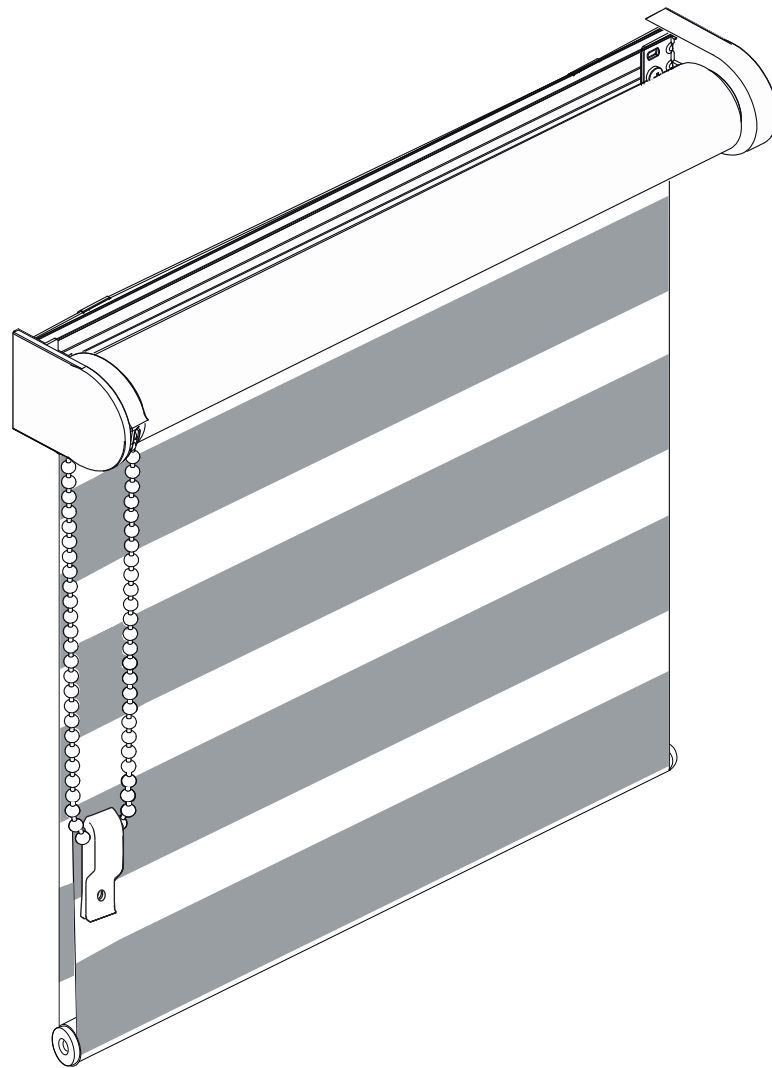

Day & Night Roller Blind

Store Enrouleur Jour Nuit

Roleta Dzień i Noc

Estor Noche y Día

Duorol gordijn

Tenda Giorno e Notte

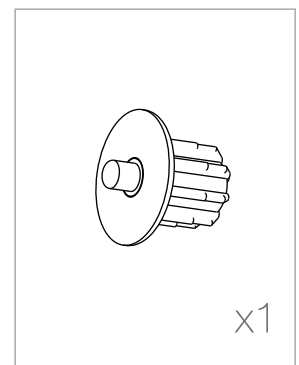
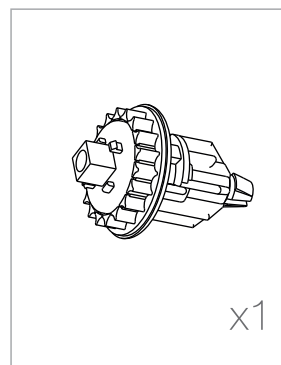
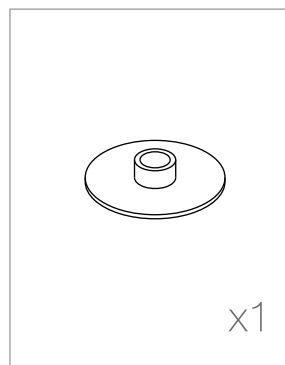
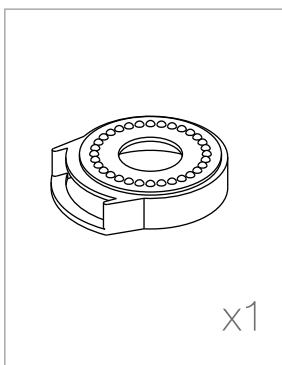
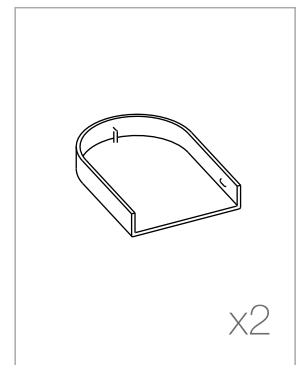
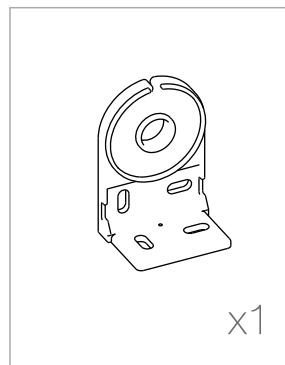
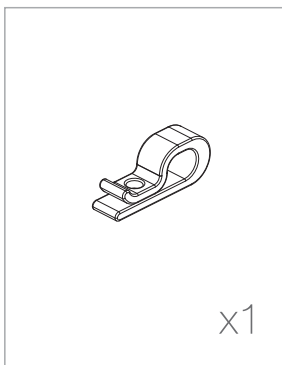
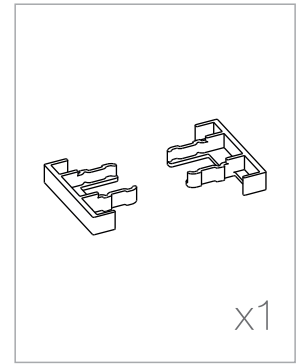
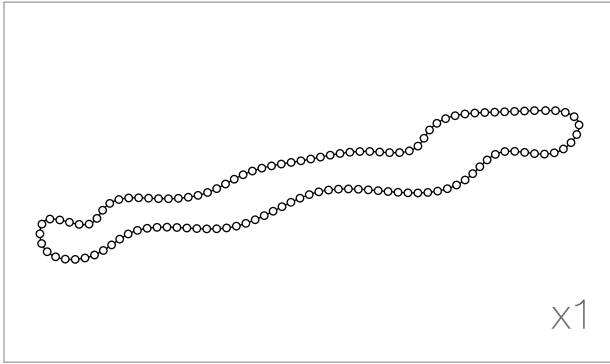
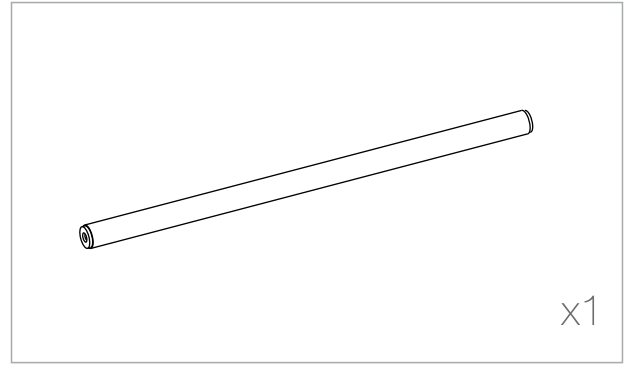
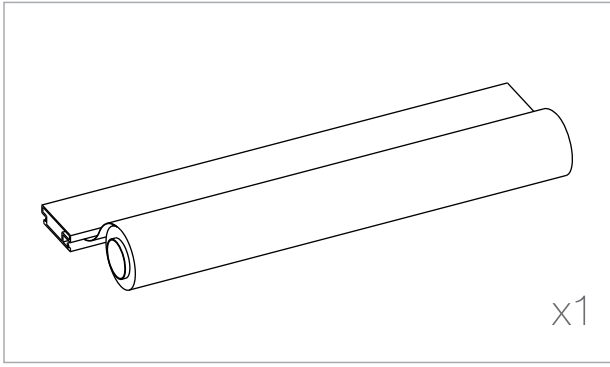

Attention!

Please do not lower the blind fully. Once the blind is lowered there should be an extra fabric left on the shaft. Otherwise the fabric may peel off. If that happens due to inappropriate usage the product will lose its warranty.

Attention !

Lors de l'utilisation du store enrouleur jour nuit, il n'est pas nécessaire de le baisser jusqu'au bout. Après avoir enroulé le store, au moins un rouleau de tissu devrait rester autour du tube d'enroulement, sinon le tissu risque de se décoller. La réclamation ne sera pas reconnue si le tissu s'est décollé à cause d'une mauvaise utilisation.

Let op!

Tijdens gebruik mag de rolgordijn niet volledig worden uitgerold. Nadat het rolgordijn is uitgerold, op de buis moet ten minste één laag stof overblijven. Anders kan de stof los gaan. Als de stof loslaat als gevolg van onjuist gebruik, we accepteren de klacht niet.

Uwaga!

W trakcie użytkowania nie należy rozwijać rolety do końca. Po zwinięciu rolety, na rurce powinien zostać co najmniej jeden zwój tkaniny. W przeciwnym razie tkanina może się odkleić. W przypadku odklejenia się tkaniny w wyniku złego użytkowania reklamacji nie uznajemy.

¡Atención!

Al momento de usar no hay que recoger el estor hasta el final. Tras el enrollamiento del estor, en el eje debe haber por lo menos un rollo de tela. De lo contrario, la tela se puede desprender. No aceptamos una reclamación en el caso de que la tela se desprenda a causa del uso incorrecto.

Attenzione!

Durante l'uso, la tenda non deve essere srotolata completamente. Dopo averla arrotolata, sul tubo deve rimanere almeno un rotolo di tessuto, altrimenti il tessuto può staccarsi. Non si accettano reclami in caso in cui il tessuto si stacchi a causa di un uso improprio.

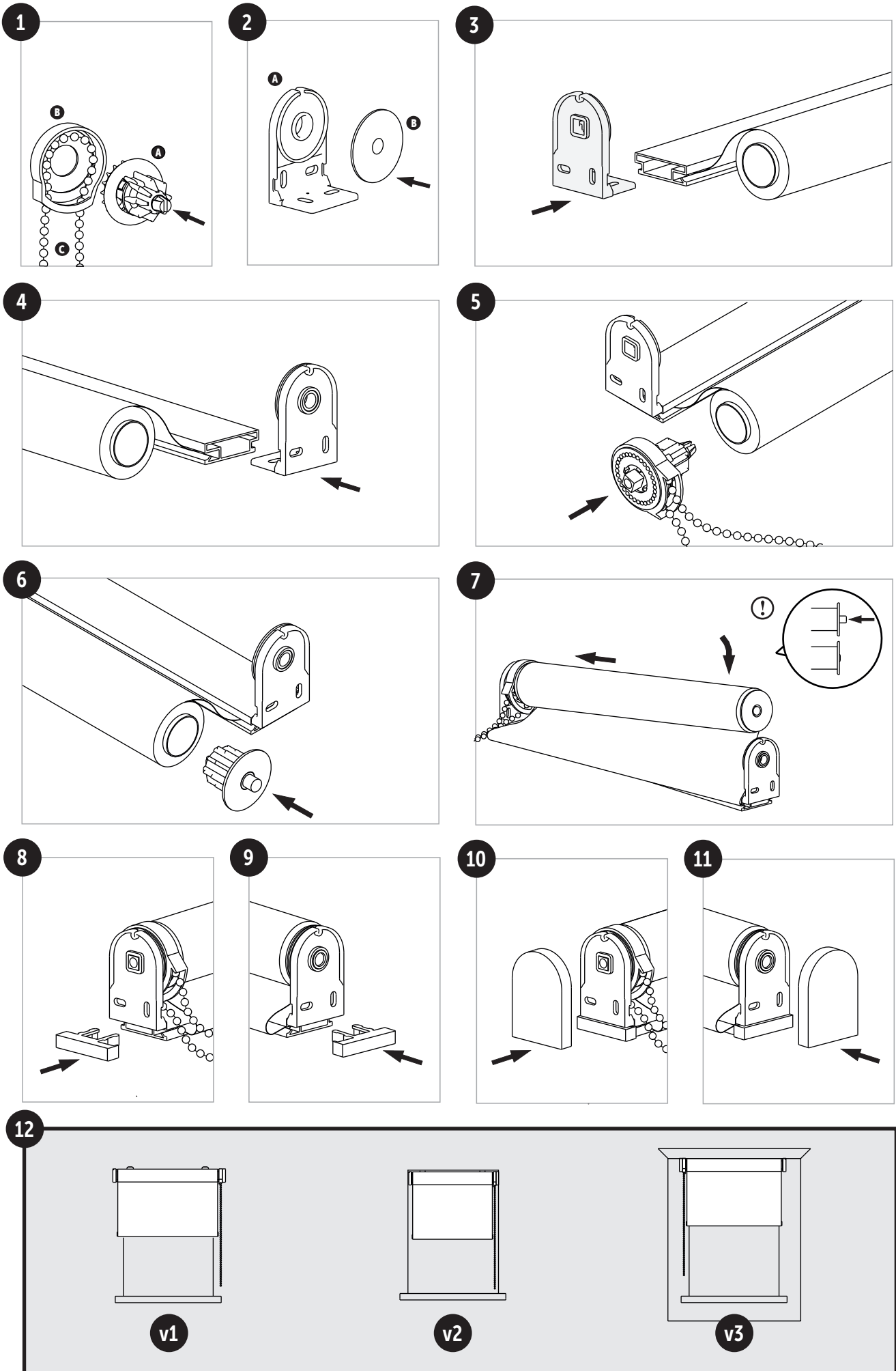

v1

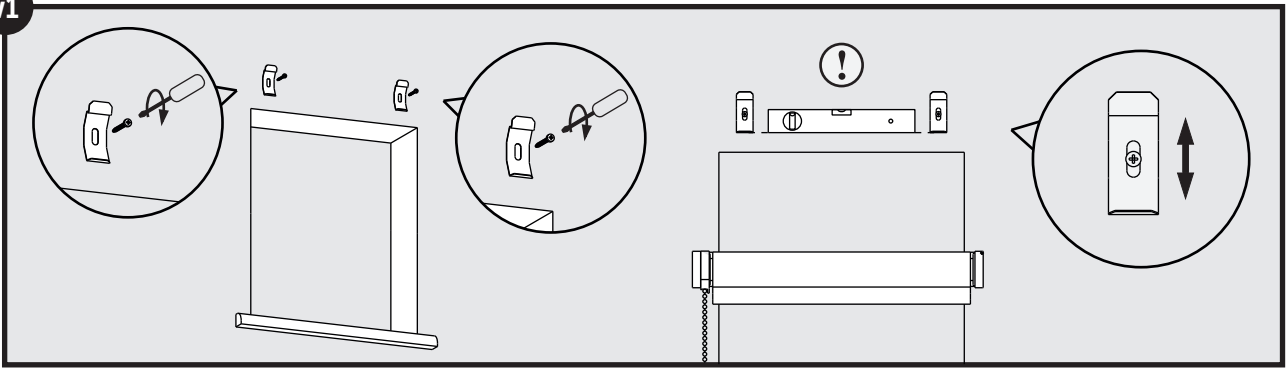

13

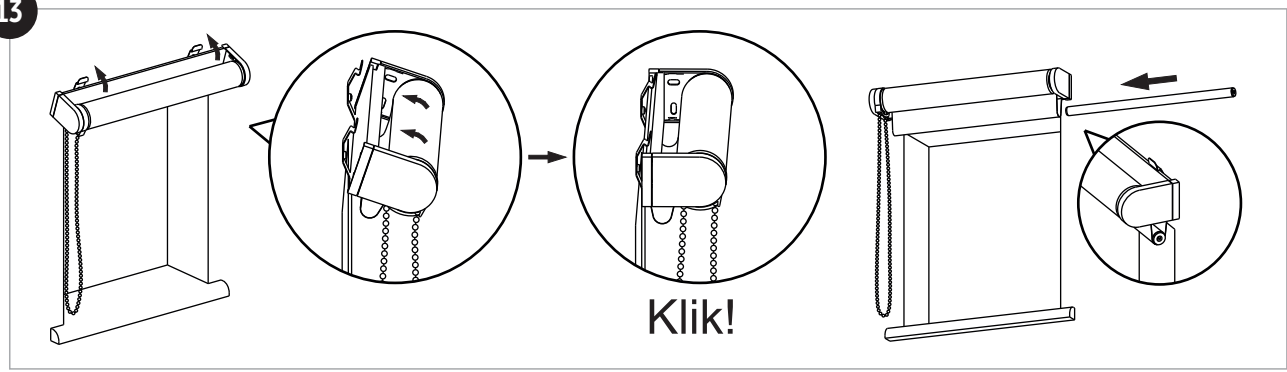

v2

v3

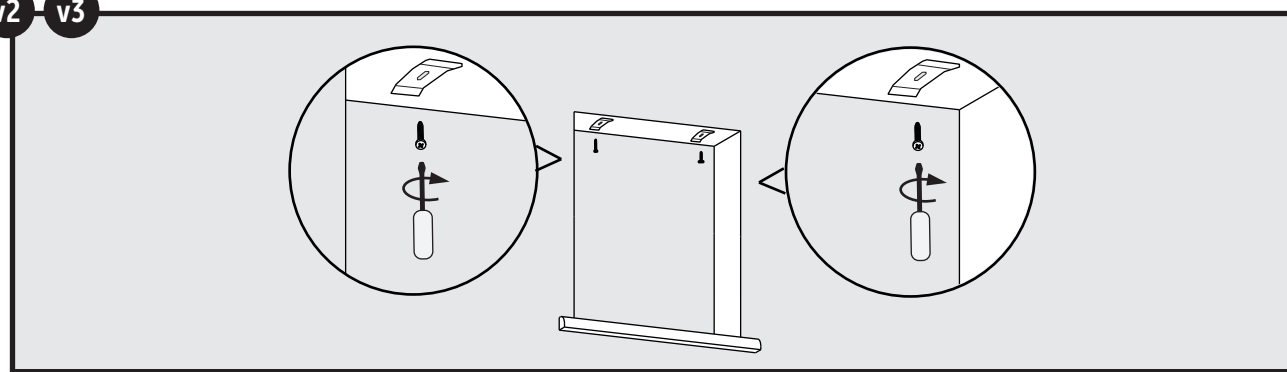

13

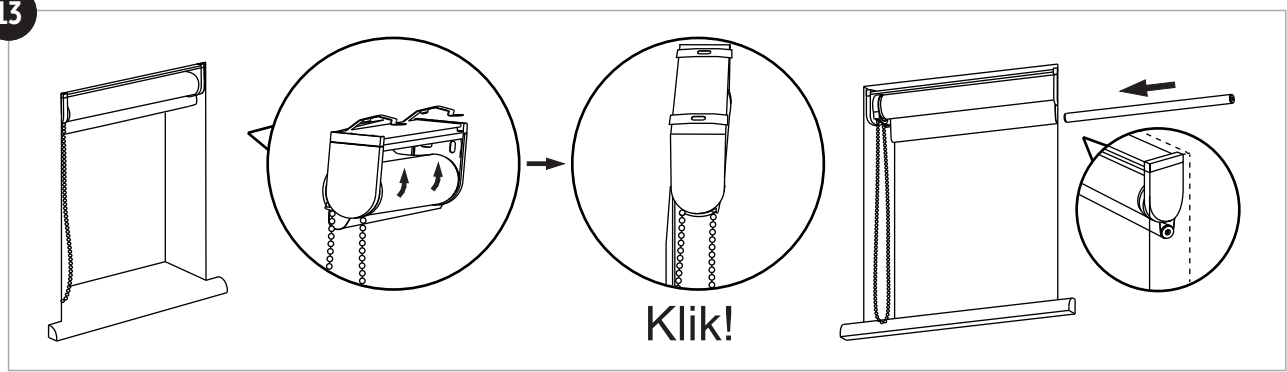

14

